

ABB MEASUREMENT & ANALYTICS | DATA SHEET

Sensyflow FMT500-IG

Thermal Mass Flowmeter



Measurement made easy

Digital mass flowmeter for air, gas and gas mixtures in process applications

Direct mass flow measurement of gases

- No additional pressure and temperature compensation

Wide measuring range up to 1:150

- Factory calibration with optional DAkkS / ILAC certificate
- Process gas calibration with clean gases and gas mixtures (optional)

High measuring accuracy; short response time ≤ 0.5 s; negligible pressure loss; no moving parts, no maintenance, no wear

Defined and reproducible mounting position in the middle of the piping

- Pipe components for DN 25 to 200 (1 to 8 in), welding adapter for larger diameters and rectangular ducts, reliable and convenient hot tap fittings

Contents

1	General information	4
1.1	Principle of operation and construction	4
1.2	Type overview	5
1.3	Overview of Sensyflow FMT500-IG	6
2	Specifications	7
3	Electrical connections	9
4	Ex relevant specifications	14
4.2	Safety Specifications for the Inputs and Outputs, Model FCM2000-MC27B	16
5	Communication	18
5.1	HART	18
5.2	PROFIBUS DPV1	18
6	Dimensions	19
7	Installation instructions	21
7.1	Weld-on adapter for Sensyflow FMT500-IG	21
7.2	Weld-on adapter with ball valve for Sensyflow FMT500-IG	22
7.3	Integrated hot tap fitting for Sensyflow FMT500-IG	23
8	Recommended steadying lengths according to DIN EN ISO 5167-1	25
9	Ordering information	26
9.1	Additional ordering information	29
10	Questionnaire	30

1 General information

1.1 Principle of operation and construction

Sensyflow FMT500-IG is a thermal flowmeter for gases. The measuring principle (hot-film anemometer) allows the direct determination of mass flow and gas temperature. Taking the standard density of the gases into consideration, the standard volume flow rate can be displayed without additional pressure and temperature compensation.

The integral mount design of the Sensyflow FMT500-IG metering system comprises a transmitter, flowmeter sensor and a pipe component. In the remote design the flowmeter sensor and the transmitter are connected via a max. 50 m (164 ft.) long cable. Depending on the version, the flowmeter sensor provides the measuring signals either as PROFIBUS or as analog / HART signals. The unit is operated either remotely via PROFIBUS / HART communication or locally by using a magnetic pen.

The pipe component is available for nominal pipe sizes ranging from DN 25 ... DN 200 and in various designs. It is also possible to install the flowmeter sensor directly in square ducts or pipes with any diameter via a weld-on adapter.

For many years, thermal gas-mass flowmeters with analog design have been established as complete process measuring devices in the chemical industry. The digital Sensyflow FMT500-IG represents a logical step in the consequent development of this well-proven technology.

Physics of measurement

Thermal flow metering procedures use different ways to evaluate the flow dependent cooling of a heated resistor as measuring signal. In a hotfilm anemometer with temperature difference control, the heated platinum resistor is maintained at a constant overtemperature in relation to an unheated platinum sensor inside the gas flow. The heating power required for maintaining the overtemperature depends directly on the flow rate and the material properties of the gas. With a known (and constant) gas composition the mass-flow can be determined by electronically evaluating the heater current / mass-flow curve without additional pressure and temperature compensation. When using the constant power method, the temperature difference is measured which results from a constant heating power and depends on the heat quantity dissipated by the gas mass flow as well. Together with the standard density of the gas this results directly in the standard volume flow. Considering the high measuring range dynamics up to 1:150, an accuracy smaller than 1 % of the measuring value is achieved.

The digital Sensyflow method

With the patented digital Sensyflow method there are 4 signals available to the evaluation electronics. These include, besides the heating power, the temperatures of the fluid and the heated sensor element, which can thus be used to compensate the temperature dependency on gas characteristics. By storing the gas data in the measuring system it is possible to calculate and perform an optimum adaptation at any operating time.

Advantages of the digital concept

- By providing several primary and secondary signals these signals can be output in parallel via the fieldbus connection. This makes a gas temperature measurement unnecessary.
- Through the implementation of complete digital signal processing it is possible to adapt the sensor control and signal conditioning to the process. This means that it is possible to achieve optimum measuring dynamics at all times, even under changing operating conditions.
- The digital Sensyflow method is capable of providing a further enhanced measuring range.



Abb. 1: Digital measuring principle of FMT500-IG

1	CPU and signal processing
q_m	Gas mass flow
T_G	Gas temperature
A/D	Alarms, diagnostics
U_{HS}	Heater setpoint
I_{HI}	Process value of heater
U_{HI}	Process value of heater
T_{HI}	Process value of heater
T_{GI}	Process value of gas
R_{MG}	Gas temperature measuring resistor
R_{MH}	Heater temperature measuring resistor
R_H	Heating resistor
P_H	Heating power

- While controlling the heater power at the same time, the temperature measurement of the heating resistor sets a limit of this temperature. If errors occur in the system resulting in gas temperatures beyond the specification, the heating power is switched off and the device sends a substitute value with an additional warning signal. Both measures result in a significant prolongation of the service life for high-temperature operation and enhanced equipment safety for the user.
- The most significant application and cost advantage results from the diagnostic features of the digital Sensyflow. The functions provided allow for preventive maintenance of the measuring system and the equipment, as operating times, temperature peaks and loads in the system can be evaluated, stored, and reported. This leads to direct cost savings by preventing failures and equipment downtime.

Typical applications

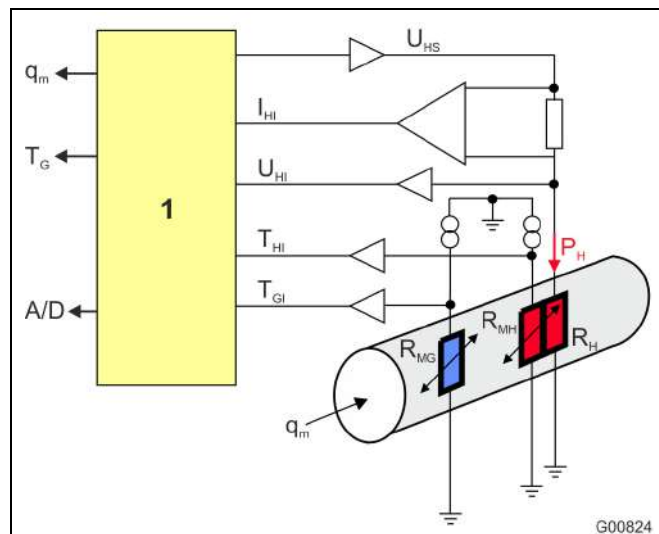
- Gas volume measurement in chemical industry and process technology
- Compressed air balancing
- Gas burner control systems
- Biogas and activation air measurement in sewage plants
- Gas measurement at air decomposers
- Hydrogen measurement in the process

1.2 Type overview

Type	FMT500-IG	FMT500-IG explosion-proof design
Application area	Process technology	
Measuring gas	Gas and gas mixtures with known composition	
Explosion protection	Manufacturer's Declaration ATEX II 3 G and II 3 D, Zone 2/22	KEMA 03ATEX2100 Certificate ATEX II 1/2 G and II 2 D, Zone 0, 1, 21 FM Cl.1 Div. 1 or Cl.1 Div. 2
Design / dimensions / weight	depends on the nominal diameter	
Material (standard)	Stainless steel, ceramic sensor (other materials on request)	
Process connection (standard)	Flanges in accordance with EN1092-1 Form B1, PN 40 (DIN 2635 Form C) or ASME B 16.5 Cl. 150 / 300	
System components	Transmitter Sensor Pipe component in design 1 or 2 or welding adapter	
Standard pipe nominal diameters	Type 1 pipe component: Wafer type DN 40, 50, 65, 80, 100, 125, 150, 200 – ASME 1 1/2", 2", 3", 4", 6", 8" Type 2 pipe component: Partial measuring section DN 25, 40, 50, 65, 80 – ASME 1", 1 1/2", 2" Welding adapter for rectangular ducts or pipe diameters ≥ DN 100 (4")	
IP rating	IP 67 (IP 66 for sensor remote mount design)	

Device configuration and functions

- Illuminated graphic display, 120 x 32 pixels
- Measurement of mass or standard volume flow, measured values are displayed as numbers or in bar charts
- Totalizer function with start / stop, reset and preset function
- Measurement of gas temperature
- 4 characteristic curves for different gases or pipe diameters (optional)
- Max. / Min. value storage for flow, gas temperature, and housing temperature
- Alarm and limit value functions
- Status and diagnostic signals
- Operating hours counter
- Simulation of measured values and status signals
- Users can adjust measured values locally
- Password-protected data entry menus
- Menu navigation in 4 languages
- Local operation with magnet stick
- FDT / DTM for parameterization with ASSET VISION DAT200 and DTM400 or control system
- Easy setup menu (analog / HART version) makes getting started easy
- Manufacturer's declaration regarding safety-related information according to IEC 61508 for analog / HART version (optional)

PROFIBUS DPV1 version communication

- According to PA profile 3.0, max. transmission rate 1.5 Mbaud, direct connection to intrinsically safe PROFIBUS DP possible in hazardous areas

Signal outputs and inputs analog / HART version

- HART communication via 4 ... 20 mA analog signal
- Current output for flow value
- 2 open-collector digital outputs, can be parameterized as:
 - Frequency output for flow and gas temperature
 - Pulse output for totalizer
 - Switching output for limit values and single or collective alarm
- 2 digital inputs, can be parameterized as:
 - External characteristic curve switchover
 - Totalizer start / stop or reset
- 24 V DC output for input/output wiring or transmitter power supply (30 mA max., not for hazardous area versions)

1.3 Overview of Sensyflow FMT500-IG

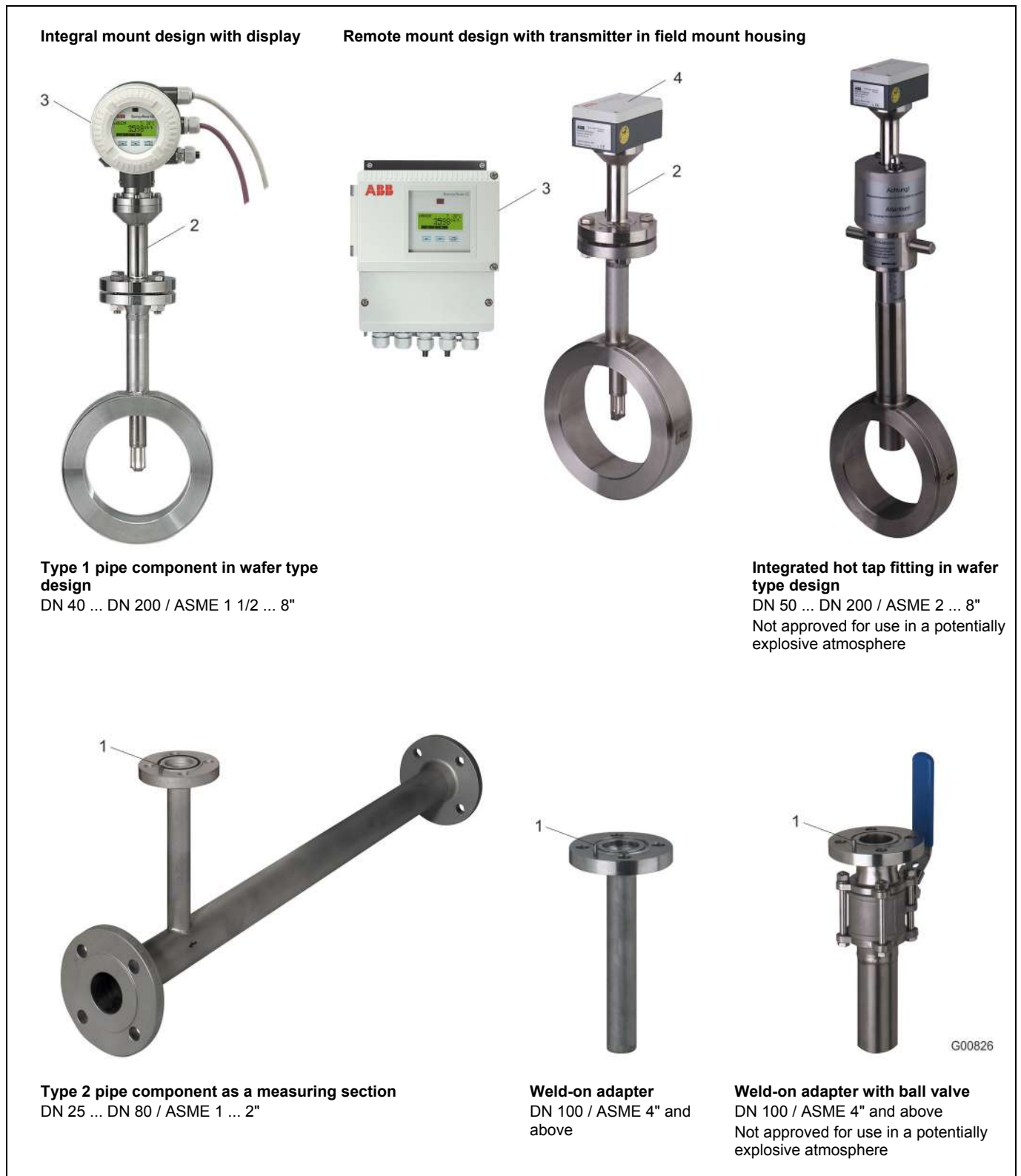

Fig. 2

- | | | | |
|---|----------------------------|---|--------------|
| 1 | Centering pin outflow side | 3 | Transmitter |
| 2 | FMT500-IG Sensor | 4 | Terminal box |

2 Specifications

Type	FMT500-IG						FMT500-IG Hazardous area design					
Measured variable (measured gases)	Flow of gases and gas mixtures with known composition											
Measuring ranges Nominal diameters (DN)	q_{min} kg/h	q_{max} kg/h	q_{min} Nm ³ /h	q_{max} Nm ³ /h	q_{min} kg/h	q_{max} kg/h	q_{min} Nm ³ /h	q_{max} Nm ³ /h	q_{min} kg/h	q_{max} kg/h	q_{min} Nm ³ /h	q_{max} Nm ³ /h
	For 0 °C (32 °F) / 1013.25 hPa (14.696 psia)						For 0 °C (32 °F) / 1013.25 hPa (14.696 psia)					
DN 25	0 ...	180	0 ...	140	0 ...	160	0 ...	120	0 ...	160	0 ...	120
DN 40	0 ...	450	0 ...	350	0 ...	430	0 ...	330	0 ...	430	0 ...	330
DN 50	0 ...	750	0 ...	580	0 ...	700	0 ...	540	0 ...	700	0 ...	540
DN 65	0 ...	1,400	0 ...	1,100	0 ...	1,200	0 ...	920	0 ...	1,200	0 ...	920
DN 80	0 ...	2,000	0 ...	1,500	0 ...	1,700	0 ...	1,300	0 ...	1,700	0 ...	1,300
DN 100	0 ...	3,200	0 ...	2,500	0 ...	3,000	0 ...	2,300	0 ...	3,000	0 ...	2,300
DN 125	0 ...	5,600	0 ...	4,300	0 ...	5,100	0 ...	3,900	0 ...	5,100	0 ...	3,900
DN 150	0 ...	9,000	0 ...	7,000	0 ...	8,000	0 ...	6,200	0 ...	8,000	0 ...	6,200
DN 200	0 ...	15,000	0 ...	12,000	0 ...	13,000	0 ...	10,000	0 ...	13,000	0 ...	10,000
Up to 3000 mm	0 ...	3,000,000	0 ...	2,300,000	0 ...	2,700,000	0 ...	2,100,000	0 ...	2,700,000	0 ...	2,100,000
(rectangular ducts and larger diameters on request)												
Measuring ranges Nominal diameters (inch)	q_{min} lbs/h	q_{max} lbs/h	q_{min} SCFM	q_{max} SCFM	q_{min} lbs/h	q_{max} lbs/h	q_{min} SCFM	q_{max} SCFM	q_{min} lbs/h	q_{max} lbs/h	q_{min} SCFM	q_{max} SCFM
	For 15 °C (59 °F) / 1013.25 hPa (14.696 psia)						For 15 °C (59 °F) / 1013.25 hPa (14.696 psia)					
1.0	0 ...	350	0 ...	75	0 ...	310	0 ...	65	0 ...	310	0 ...	65
1.5	0 ...	880	0 ...	190	0 ...	860	0 ...	185	0 ...	860	0 ...	185
2.0	0 ...	1,500	0 ...	330	0 ...	1,400	0 ...	310	0 ...	1,400	0 ...	310
3.0	0 ...	4,000	0 ...	860	0 ...	3,300	0 ...	720	0 ...	3,300	0 ...	720
4.0	0 ...	6,400	0 ...	1,400	0 ...	6,000	0 ...	1,300	0 ...	6,000	0 ...	1,300
6.0	0 ...	18,500	0 ...	4,000	0 ...	16,500	0 ...	3,600	0 ...	16,500	0 ...	3,600
8.0	0 ...	32,000	0 ...	6,900	0 ...	27,500	0 ...	6,000	0 ...	27,500	0 ...	6,000
120.0	0 ...	6,600,000	0 ...	1,400,000	0 ...	6,000,000	0 ...	1,300,000	0 ...	6,000,000	0 ...	1,300,000
(rectangular ducts and larger diameters on request)												
Notes regarding measuring ranges	<p>The above values are reference values for applications involving air or nitrogen under atmospheric conditions (other gases available upon request).</p> <p>The values for q_{max} can be increased by approx. 10 % upon request (with lower accuracy in the extended range).</p> <p>For hydrogen and helium, the measuring range lower limit is typically approx. 10 % of the upper limit.</p>											
Measuring errors Air, nitrogen	<p>Under calibration conditions in specified measuring range</p> <p>≤ ± 0.9 % of the measured value ± 0.05 % of the possible end value in this nominal diameter (see measuring ranges)</p>											
other gases	<p>≤ ± 1.8 % of the measured value ± 0.10 % of the possible end value in this nominal diameter (see measuring ranges)</p> <p>Special calibration on request</p>											
Reproducibility	< 0.2 % of the measured value, t _{meas} = 10 s											
Effect of the temperature of the measured medium	< 0.05 % / K of the measured value (depending on the type of gas)											
Effect of the pressure of the measured medium	< 0.2 % / 100 kPa (/ bar) of the measured value (depending on the type of gas)											
Response time	T ₆₃ = 0.5 s T ₆₃ = 2 s for zone 2/22 version with constant power method						T ₆₃ = 2 s					

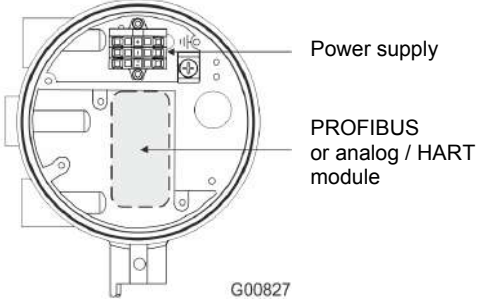
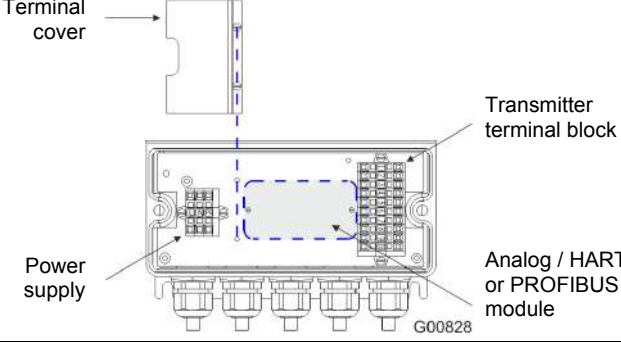
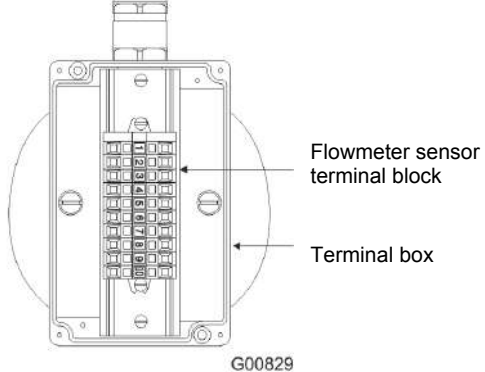

Type	FMT500-IG	FMT500-IG Ex version
Operating conditions		
Recommended inlet and outlet runs	According to DIN EN ISO 5167-1 Minimum inlet run 15 x pipe diameter D, outlet run 5 x pipe diameter D	
Environmental conditions		
Ambient temperature Transmitter	-25 ... 50 °C (-13 ... 122 °F) for zone 2/22 versionen: -20...50 °C (-4 ... 122 °F)	-20 ... 50 °C (-4 ... 122 °F)
Flowmeter sensor remote design	-25 ... 80 °C (-13 ... 176 °F) for zone 2/22 versionen: -20 ... 80 °C (-4 ... 176 °F)	-20 ... 80 °C (-4 ... 176 °F)
Other ambient temperatures on request		
Storage temperature	-25 ... 85 °C (-13 ... 185 °F)	
Type of protection	IP 67 (IP 66 for flowmeter sensor remote design)	
Process conditions		
Operating temperature Measuring medium (flowmeter sensor)	Standard range: -25 ... 150 °C (-13 ... 302 °F) Extended range: -25 ... 300 °C (-13 ... 572 °F) Zone 2/22 version: -20 ... 150 °C (-4 ... 302 °F)	acc. to temperature classes of Ex certificates max. -20 ... 150 °C (-4 ... 302 °F) (-40 °C version on request)
Operating pressure	4 x 10 ⁶ Pa (40 bar [580 psi])	
Pressure loss (logarithmic diagram)	<p>< 1.0 kPa (10 mbar [0.1450 psi]), typical value 0.1 kPa (1 mbar [0.0145 psi])</p> <p style="text-align: right;">G00796</p>	
Power supply		
Voltage	Universal power supply unit: 110 ... 230 V AC/DC ± 10 % (f = 48 ... 62 Hz) Low-voltage power supply unit: 24 V AC/DC ± 20 % (f = 48 ... 62 Hz)	
Power consumption	20 VA, current consumption 800 mA, slow-blow fuse of at least 2 A required	
Cable entry	M20 x 1.5 or 1/2" NPT	
Output		
Analog- / HART version Analog output Digital outputs Digital inputs	<p>0/4 ... 20 mA, load < 600 Ω (IG-Ex < 400 Ω), electrical isolated, alert < 3.5 or > 22 mA</p> <p>2 x passive optocoupler (approx. 100 mA) can be used as frequency, pulse or contact output</p> <p>2 x 24 V lin typ. 10 mA (low < 2 mA, high > 10 mA) contact input</p>	
Installation class	Overvoltage category III, degree of pollution 2	

3 Electrical connections

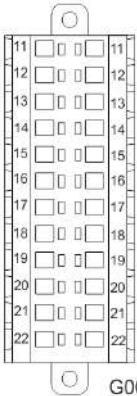
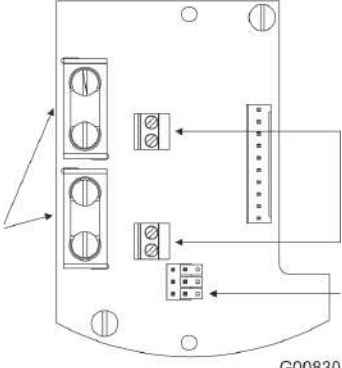
<p>Transmitter with integral mount design</p> <p>L / + Phase / + terminal N / - Neutral / - terminal PE Grounding</p> <p>Wide-range power supply unit 110 ... 230 V AC / DC \pm 10 % or Low-voltage power supply unit 24 V AC / DC \pm 20 %</p>	 <p>Power supply</p> <p>PROFIBUS or analog / HART module</p> <p>G00827</p>
<p>Transmitter with remote mount design</p> <p>L / + Phase / + terminal N / - Neutral / - terminal PE Grounding</p> <p>Wide-range power supply unit 110 ... 230 V AC / DC \pm 10 % or Low-voltage power supply unit 24 V AC / DC \pm 20 %</p> <p>1:1 cable connection from transmitter terminal block to flowmeter sensor terminal block, terminals 1 ... 10 (terminal 6 not assigned).</p>	 <p>Terminal cover</p> <p>Transmitter terminal block</p> <p>Power supply</p> <p>Analog / HART or PROFIBUS module</p> <p>G00828</p>
<p>Flowmeter sensor with remote mount design</p> <p>Flowmeter sensor Terminals 1 ... 10</p> <p>Cable Min. 9 wires</p> <p>Min. cross section Min. 0.5 mm² AWG 20</p> <p>Max. cable length 50 m (164 ft.) (25 m [82 ft.] for Zone 2/22 version with constant power method)</p> <p>1:1 cable connection from transmitter terminal block to flowmeter sensor terminal block, terminals 1 ... 10 (terminal 6 not assigned).</p> <p>Place one side of the cable shield in the metal cable gland for the terminal box.</p>	 <p>Flowmeter sensor terminal block</p> <p>Terminal box</p> <p>G00829</p>

<p>Analog / HART module</p> <p>11 Shield 12 + I_{out} analog output / HART 13 - I_{out} analog output / HART 14 + 24 V DC for external supply, 30 mA max. 15 GND 24 V 16 D_{out} 1 17 D_{out} 2 18 GND D_{out} (D_{out} 1 + 2) 19 D_{in} 1 20 D_{in} 2 21 GND D_{in} (D_{in} 1 + 2) 22 Shield</p>	 <p style="text-align: center;">G00831</p>
<p>PROFIBUS module</p> <p>A PROFIBUS DPV1 in / out signal B PROFIBUS DPV1 in / out signal</p> <p>Note: The system design is such that the entire bus connection will be interrupted if you disconnect the PROFIBUS cable on the device. As an alternative, please consider the version with DP M12 connection socket (Section 3.1.3).</p> <p>¹⁾ Note regarding terminating resistor: The bus termination with jumpers should only be used if just the device is connected to this PROFIBUS line.</p> <p>The incoming and outgoing PROFIBUS cables are connected to terminals A (green cable) and B (red cable) respectively. The other terminal blocks must not be used (CAN bus, for internal use only).</p>	 <p style="text-align: center;">G00830</p> <p>Cable shield connected to ground (PE) by means of capacitive coupling</p> <p>PROFIBUS terminals A / B</p> <p>Jumper for PROFIBUS terminating resistor¹⁾</p>

3.1.1 Marking

Transmitter with remote mount design	Flowmeter sensor with remote mount design	Integral mount design
 II 3G Ex ec IIC T4 Gc II 3D Ex tb IIIC T115°C Dc $T_{amb} = -20 \dots 50 \text{ °C} (-4 \dots 122 \text{ °F})$	 II 3G Ex ec IIC T4 Gc II 3D Ex tb IIIC T150°C Dc $T_{amb} = -20 \dots 80 \text{ °C} (-4 \dots 176 \text{ °F})$ $T_{medium} = -20 \dots 150 \text{ °C} (-4 \dots 302 \text{ °F})$	 II 3G Ex ec IIC T4 Gc II 3D Ex tb IIIC T150°C Dc $T_{amb} = -20 \dots 50 \text{ °C} (-4 \dots 122 \text{ °F})$ $T_{medium} = -20 \dots 150 \text{ °C} (-4 \dots 302 \text{ °F})$

3.1.2 Examples for connecting peripherals (Analog / HART version)



Abb. 3

3.1.3 PROFIBUS DPV1 communication with DP M12 connector socket

The version with PROFIBUS DP M12 connector socket allows disconnection of the device from the bus without interrupting PROFIBUS DP operation. Instead of the center cable gland an assembled and wired DP M12 connector socket is supplied.

For connection to the PROFIBUS DP line you need 1 T-plug, cable socket and cable plug (see accessories).

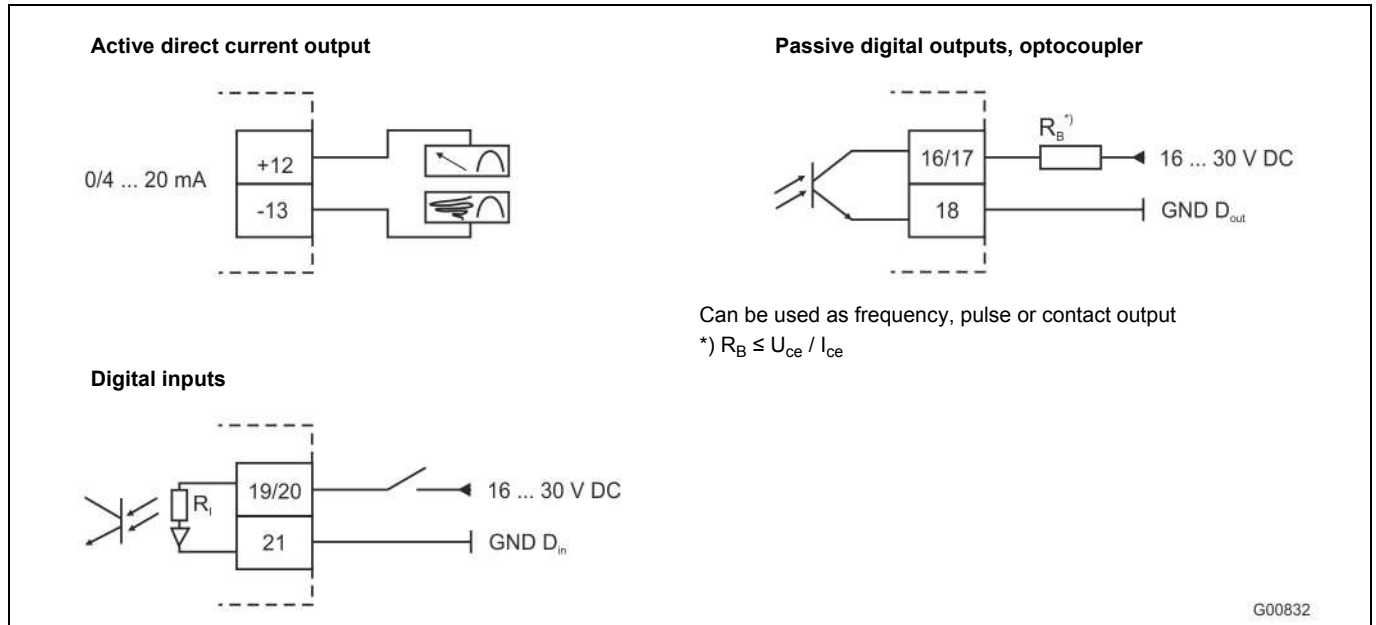
Type of protection of the plug-in connections: IP 66.

Only available for non-Ex devices in integral mount design.

Please refer to Data Sheet 10/63-6.40 for other versions of T-plugs and appropriate DP connector plugs.

Pin assignment of the device

Pin	Signal	Description
1	VP	+ 5 V
2	RxD/TxD-N	Receive / transmit data line A (green wire)
3	DGND	Data transmission potential
4	RxD/TxD-P	Receive / transmit data line B (red wire)
5	Shield	Shield / protective earth
Thread	Shield	Shield / protective earth

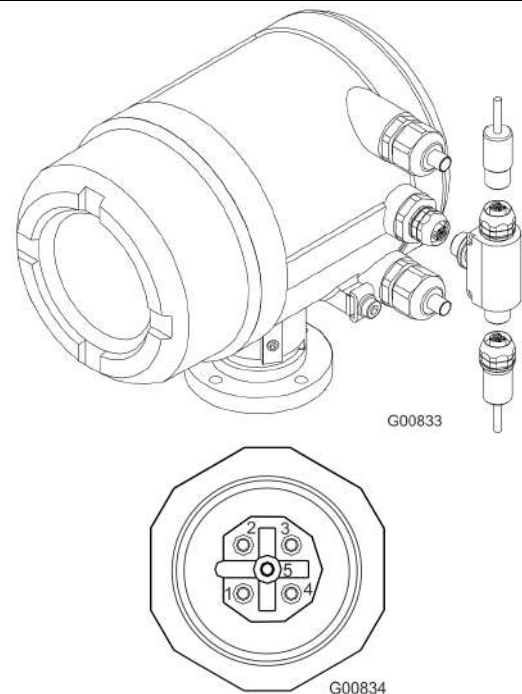

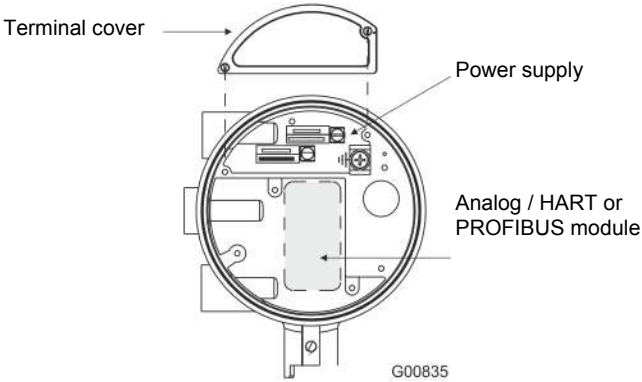
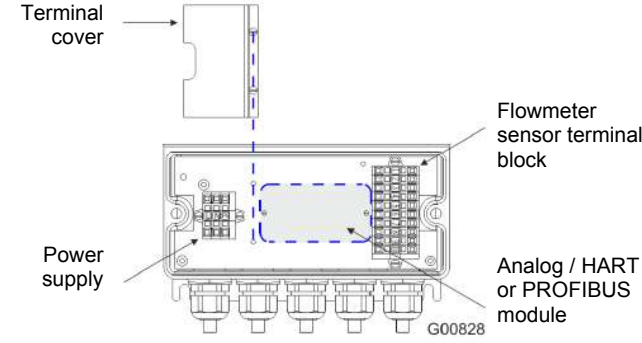
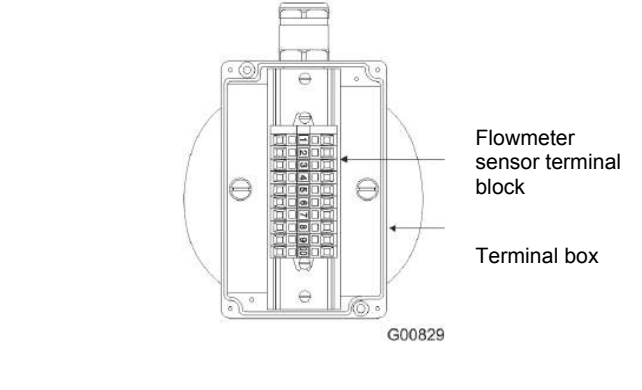
<p>Transmitter with integral mount design</p> <p>L / + Phase / + Terminal N / - Neutral / - Terminal PA Potential equalization</p> <p>Wide-range power supply unit 110 ... 230 V AC / DC \pm 10 %, 20 VA 48 ... 62 Hz, U_{max} = 250 V or Low-voltage power supply 24 V AC / DC \pm 20 %, 20 VA 48 ... 62 Hz, U_{max} = 29 V</p> <p>Type of protection for power supply connection Ex e (ATEX), XP (FM) Before opening the cover to the connection area, remove the safety locking device and reattach it after closing the housing.</p>	 <p>Terminal cover</p> <p>Power supply</p> <p>Analog / HART or PROFIBUS module</p> <p>G00835</p>
<p>Transmitter with remote mount design</p> <p>L / + Phase / + Terminal N / - Neutral / - Terminal PE Grounding</p> <p>Wide-range power supply unit 110 ... 230 V AC / DC \pm 10 %, 20 VA 48 ... 62 Hz, U_{max} = 250 V or Low-voltage power supply unit 24 V AC / DC \pm 20 %, 20 VA 48 ... 62 Hz, U_{max} = 29 V</p> <p>1:1 cable connection from transmitter terminal block to flowmeter sensor terminal block, terminals 1 ... 10 (terminal 6 not assigned)</p> <p>Type of protection for sensor connection Ex ia (ATEX), IS (FM)</p>	 <p>Terminal cover</p> <p>Power supply</p> <p>Flowmeter sensor terminal block</p> <p>Analog / HART or PROFIBUS module</p> <p>G00828</p>
<p>Flowmeter sensor with remote mount design</p> <p>Type of protection Ex ia (ATEX), IS (FM) Sensor Terminal 1 ... 10 Cable min. 9 wires Minimum cross-section min. 0.5 mm² AWG 20 Max. cable length 25 m (82 ft.)</p> <p>1:1 cable connection from transmitter terminal block to flowmeter sensor terminal block, terminals 1 ... 10 (terminal 6 not assigned)</p>	 <p>Flowmeter sensor terminal block</p> <p>Terminal box</p> <p>G00829</p>

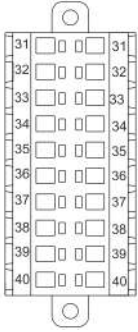
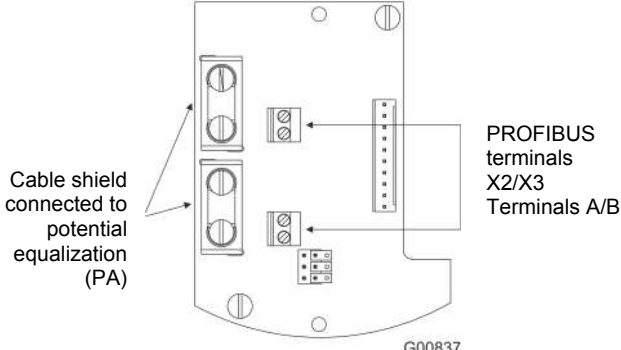
<p>Analog / HART module</p> <p>31 + I_{out} analog output / HART 32 - I_{out} analog output / HART 33 D_{out} 1 34 GND D_{out} (D_{out} 1) 35 D_{out} 2 36 GND D_{out} (D_{out} 2) 37 D_{in} 1 38 GND D_{in} (D_{in} 1) 39 D_{in} 2 40 GND D_{in} (D_{in} 2)</p> <p>Type of protection: Ex ib or Ex e (ATEX), IS or XP, NI (FM) When connecting the fieldbus / signal lines, the safety-related parameters in the relevant certificates must be observed.</p>	 <p style="text-align: right;">G00836</p>
<p>PROFIBUS module</p> <p>A PROFIBUS DPV1 in / out signal B PROFIBUS DPV1 in / out signal Type of protection Ex ib (ATEX), IS (FM)</p> <p>Connect to intrinsically safe PROFIBUS DP only (integral and remote mount designs) Bus termination internally via 150 Ω resistor or externally in accordance with the RS485 IS specification</p> <p>When connecting the fieldbus/signal lines, the safety-related parameters in the relevant certificates must be observed.</p>	 <p style="text-align: right;">G00837</p>

4 Ex relevant specifications

4.1.1 Options regarding installation in potentially explosive atmospheres

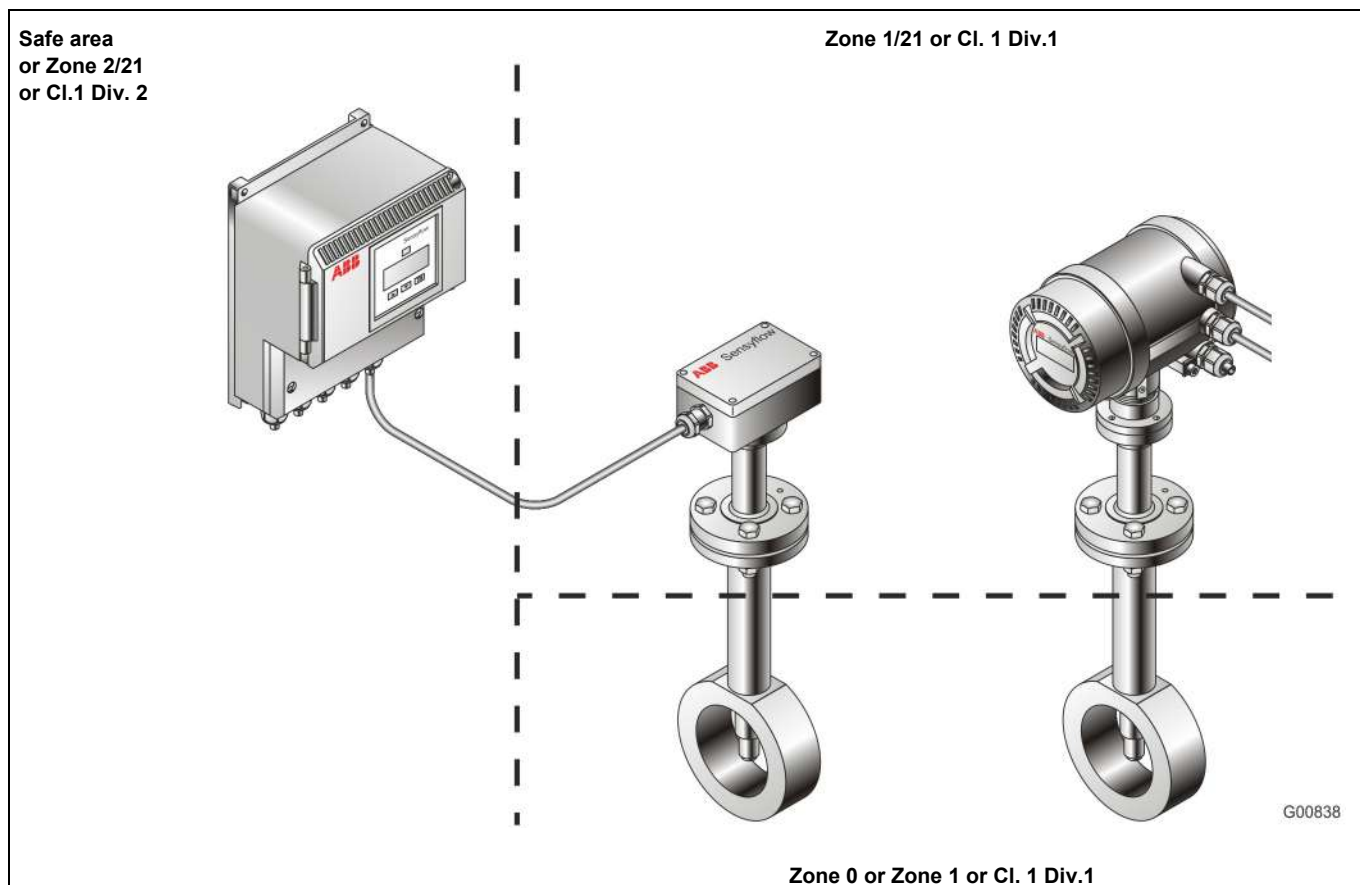

4.1.2 ATEX Marking



Transmitter, remote mount design	Flowmeter sensor, remote mount design	Integral mount design
Zone 2/21 Ex II3(1)G Ex ec [ia][ib] IIC T4 Gc II 2D Ex tb IIIC T115°C Db T _{amb} = -20 ... 50 °C (-4 ... 122 °F)	Terminal box Zone 1, flowmeter sensor Zone 0 Ex II 1/2G Ex ia IIC T4 Ga II 2D Ex tb IIIC T80°C Db Terminal box and flowmeter sensor Zone 1 Ex II 2G Ex ia IIC T4 Gb II 2D Ex tb IIIC T100°C or 200°C or 300°C Db T _{amb} = -20 ... 80 °C (-4 ... 176 °F)	Transmitter Zone 1, flowmeter sensor Zone 0 Ex II 1/2G Ex db eb [ia][ib] IIC T4 Ga II 2D Ex tb IIIC T115°C Db Transmitter and flowmeter sensor Zone 1 Ex II 2G Ex db eb [ia][ib] IIC T4...T1 Gb II 2D Ex tb IIIC T100°C or 200°C or 300°C Db T _{amb} = -20 ... 50 °C (-4 ... 122 °F)
Optional -40 °C for ambient temperature	Optional -40 °C for ambient temperature	Optional -40 °C for ambient temperature

4.1.3 Temperature table for ATEX designs

Sensyflow FMT500-IG, integral mount design				
Temperature class	Surface temperature	Process temperature	Sensor	Transmitter
T4	T 115 °C	-20 ... 80 °C (-4 ... 176 °F)	Cat. 1G / Zone 0	Cat. 2G/2D / Zone 1/21
T4	T 115 °C	-20 ... 100 °C (-4 ... 212 °F)	Cat. 2G / Zone 1	Cat. 2G/2D / Zone 1/21
T3	T 115 °C	-20 ... 100 °C (-4 ... 212 °F)	Cat. 2G / Zone 1	Cat. 2G/2D / Zone 1/21
T2	T 200 °C ¹⁾	-20 ... 200 °C (-4 ... 392 °F) ¹⁾	Cat. 2G / Zone 1	Cat. 2G/2D / Zone 1/21
T1	T 300 °C ¹⁾	-20 ... 300 °C (-4 ... 572 °F) ¹⁾	Cat. 2G / Zone 1	Cat. 2G/2D / Zone 1/21
Sensyflow FMT500-IG transmitter, remote mount design				
Temperature class	Surface temperature			Transmitter
T4	T 115 °C			Cat. 3G/2D / Zone 2/21
Sensyflow FMT500-IG flowmeter sensor, remote mount design				
Temperature class	Surface temperature	Process temperature	Sensor	Terminal box
T4	T 80 °C	-20 ... 80 °C (-4 ... 176 °F)	Cat. 1G / Zone 0	Cat. 2G/2D / Zone 1/21
T4	T 100 °C	-20 ... 100 °C (-4 ... 212 °F)	Cat. 2G / Zone 1	Cat. 2G/2D / Zone 1/21
T3	T 100 °C	-20 ... 100 °C (-4 ... 212 °F)	Cat. 2G / Zone 1	Cat. 2G/2D / Zone 1/21
T2	T 200 °C ¹⁾	-20 ... 200 °C (-4 ... 392 °F) ¹⁾	Cat. 2G / Zone 1	Cat. 2G/2D / Zone 1/21
T1	T 300 °C ¹⁾	-20 ... 300 °C (-4 ... 572 °F) ¹⁾	Cat. 2G / Zone 1	Cat. 2G/2D / Zone 1/21

¹⁾ Temperatures in accordance with ATEX temperature classes, max. process temperature for the sensor -20 ... 150 °C (-4 ... 302 °F)

4.1.4 FM designations with temperature information

Transmitter, remote mount design	Flowmeter sensor, remote mount design	Integral mount design
 <p>NI CLASS I DIV2 Group: A,B,C,D, CLASS I Zone 2 AEx nA IIC T4...T1</p> <p>DIP CLASS II, III DIV1 and 2 Group: E,F,G</p> <p>IS Circuits for CLASS I DIV1 Group: A,B,C,D, CLASS I Zone 0 AEx ia IIC</p> <p>$T_{amb} = -20 \dots 50 \text{ °C} (-4 \dots 122 \text{ °F})$</p>	 <p>IS CLASS I DIV1 Group: A,B,C,D, CLASS I Zone 0 AEx ia IIC T4...T1</p> <p>DIP CLASS II, III DIV1 and 2 Group: E,F,G</p> <p>NI CLASS I, II, III DIV2, Group: A,B,C,D, CLASS I Zone 2 Group: IIC T4...T1</p> <p>$T_{amb} = -20 \dots 80 \text{ °C} (-4 \dots 176 \text{ °F})$</p> <p>$T_{medium} = -20 \dots 150 \text{ °C} (-4 \dots 302 \text{ °F})$</p> <p>$T4/T3_{medium} = -20 \dots 100 \text{ °C} (-4 \dots 212 \text{ °F})$</p> <p>$T2_{medium} = -20 \dots 200 \text{ °C} (-4 \dots 392 \text{ °F})$</p> <p>$T1_{medium} = -20 \dots 300 \text{ °C} (-4 \dots 572 \text{ °F})$</p>	 <p>XP CLASS I DIV1 Group: B,C,D, CLASS I, Zone 1 II B T4...T1</p> <p>IS Circuits for CLASS I DIV1 Group: B,C,D, CLASS I Zone 0 AEx ia IIC</p> <p>DIP CLASS II,III DIV1 and 2 Group: E,F,G</p> <p>NI CLASS I, II, III DIV2, Group: A,B,C,D,F,G, CLASS I Zone 2 Group: IIC T4...T1</p> <p>$T_{amb} = -20 \dots 50 \text{ °C} (-4 \dots 122 \text{ °F})$</p> <p>$T_{medium} = -20 \dots 150 \text{ °C} (-4 \dots 302 \text{ °F})$</p> <p>$T4/T3_{medium} = -20 \dots 100 \text{ °C} (-4 \dots 212 \text{ °F})$</p> <p>$T2_{medium} = -20 \dots 200 \text{ °C} (-4 \dots 392 \text{ °F})$</p> <p>$T1_{medium} = -20 \dots 300 \text{ °C} (-4 \dots 572 \text{ °F})$</p>

4.2 Safety Specifications for the Inputs and Outputs, Model FCM2000-MC27B

4.2.1 PROFIBUS DPV1 communication

Output circuit	ATEX design: intrinsically safe Ex ib IIC / IIB			
	FM Design IS acc. to control drawings V14224-6 ... 1222 ..., V14224-6 ... 2222 ..., V14224-7 ... 1122 ..., V14224-7 ... 2122 ...			
PROFIBUS DP	$U_o = \pm 3,72 \text{ V}$			
RS 485_IS-Interface	I_o	P_o	EEx ib IIC/IIB	
Terminals X2, X3	[mA]	[mW]	C' [nF/km]	L'/R' [mH/ Ω]
Terminal A/B	± 155	$\pm 144,2$	≤ 250	$\leq 28,5$
	Min. cable cross section 0,2 mm Max. input voltage U_i : $\pm 4,20 \text{ V}$ C_i : 0 nF Max. input current I_i : $\pm 2,66 \text{ A}$ L_i : 0 mH Electrical isolation of RS 485_IS PROFIBUS fieldbus signals A and B Cable shield is connected to potential equalization Use approved RS 485_IS interface / barriers only to disconnect intrinsically safe and non-intrinsically safe PROFIBUS connections			

4.2.2 Analog / HART communication

Output circuit	ATEX design: intrinsically safe Ex ib IIC / IIB			ATEX design: not intrinsically safe $U_{max} = 60 \text{ V}$	
	FM Design IS acc. to control drawings V14224-6 ... 1212 ... IS, V14224-6 ... 2212 ... IS, V14224-7 ... 1112 ... IS, V14224-7 ... 2112 ... IS			FM Design XP, NI, DIP acc. to control drawings V14224-6 ... 1212 ..., V14224-6 ... 2212 ..., V14224-7 ... 1112 ..., V14224-7 ... 2112 ... $U_{max} = 90 \text{ V}$	
Current output	$U_o = 17,2 \text{ V}$	$U_i = 30 \text{ V}$	$I_i = 100 \text{ mA}$		$U_B = 30 \text{ V}$
Active	I_o	P_o	Ex ib IIC		$I_B = 30 \text{ mA}$
Terminal 31 + 32	[mA]	[mW]	C_i [nF]	L_i [mH]	
	78,3	337	2,0	0,25	
	Characteristic curve: linear $C_o = 353 \text{ nF}$, $L_o = 4 \text{ mH}$ Connect to passive, intrinsically safe circuits only. Terminal 32 is connected to potential equalization (PA). Use only approved separators / barriers.				
Digital output Passive D_{out1} : Terminals 33 + 34 D_{out2} : Terminals 35 + 36	$U_i = 15 \text{ V}$ $I_i = 30 \text{ mA}$ $P_i = 115 \text{ mW}$		$C_i = 2,0 \text{ nF}$ $L_i = 0,250 \text{ mH}$		$U_B = 30 \text{ V}$ $I_B = 100 \text{ mA}$
Digital input Passive D_{in1} : Terminals 37 + 38 D_{in2} : Terminals 39 + 40	$U_i = 30 \text{ V}$ $I_i = 250 \text{ mA}$ $P_i = 1,1 \text{ W}$		$C_i = 2,0 \text{ nF}$ $L_i = 0,250 \text{ mH}$		$U_B = 30 \text{ V}$ $I_B = 100 \text{ mA}$

Special Requirements:

The output circuits are designed in such a way that they can be connected to both intrinsically safe and non-intrinsically safe circuits. It is not permitted to combine intrinsically safe and non-intrinsically safe circuits.

The rated voltage of the non-intrinsically-safe circuits is:

- for ATEX versions $U_m = 60 \text{ V}$
- for FM versions $U_m = 90 \text{ V}$ (XP, NI, DIP).

- Make sure that the terminal cover over the power supply connection is tightly closed. With intrinsically safe output circuits, the terminal box can be opened.
- For ATEX designs, use of the enclosed cable glands for the output circuits in accordance with the type of protection: intrinsically safe = blue; non-intrinsically safe = black.

- The sensor and the transmitter housing must be connected to the potential equalization. For intrinsically safe current outputs, equipotential bonding needs to be in place all the way along the circuits.
- Take into consideration the corrosion resistance of the meter tube materials to the measuring medium. This is the user's responsibility.

Note:

The values indicated here are taken from the respective certificates. The specification and supplements to the respective valid approval (ATEX, FM) are decisive.

5 Communication

5.1 HART

HART protocol Rev. 6.0 is used for digital communication between a process control system or PC, a hand-held terminal and the field device. It can be used to send all device and measuring point parameters from the transmitter to the process control system or PC. Conversely, it also provides a means of reconfiguring the transmitter.

Digital communication utilizes an alternating current superimposed on the analog output (4 ... 20 mA) that does not affect any meters connected to the output.

The ASSET VISION DAT200 and DTM400 program can be used for operation and configuration purposes. This is a piece of universal communication software for intelligent field devices based on FDT/DTM technology. Data can be exchanged with a comprehensive range of field devices using various means of communication. The main applications include parameter display, configuration, diagnostics, recording, and data management for all intelligent field devices that specifically meet the communication requirements involved.

Basic functions (such as the measuring range end value or certain mass flow units) can be parameterized with the universal HART DTM. If you use the FMT500-IG HART DTM, you will have access to the full range of functions.

Transmission method

FSK modulation at current output of 4 ... 20 mA based on the Bell 202 standard. Max. signal amplitude 1.2 mA_{SS}.

Load

Min. 250 Ω, max. 600 Ω (IG-Ex < 400 Ω)

Max. cable length 1,500 m AWG 24, twisted and shielded (for standard and Zone 2/22 devices).

Max. cable length for Ex devices depends on the safety specifications in the certificates.

Baud rate

1,200 baud

Log. 1 representation: 1200 Hz

Log. 0 representation: 2200 Hz

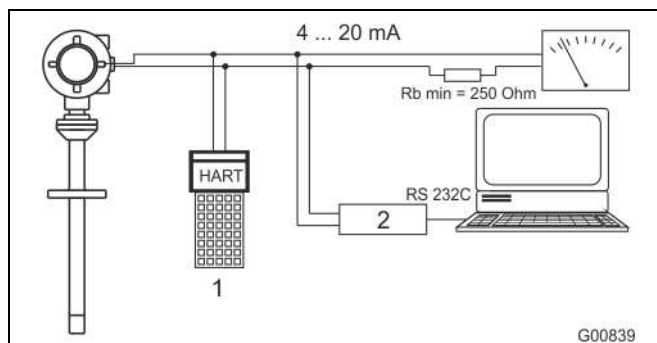

Fig. 4

- 1 Handheld terminal
- 2 FSK modem

5.2 PROFIBUS DPV1

With the Sensyflow FMT500-IG thermal mass flowmeter plus PROFIBUS interface, bus communication is based on the "Profile For Process Control Devices" Version 3.0 (PA Profile 3.0) of October 1999. PROFIBUS DP (RS 485 transmission) is used for the bus interface and the acyclic PROFIBUS DPV1 services are supported.

PROFIBUS interface parameters

- DPV1 communication without alarms
- Master C1 and C2 support
- Max. transmission rate: 1.5 Mbaud
- ID number: 0x05CA
- GSD file name: ABB_05CA.GSD

The cables for the PROFIBUS connection must meet the following parameters in accordance with PROFIBUS specification EN 50170 part 8-2:

Parameter	DP, cable type A, shielded
Surge impedance in Ω	135 ... 165 at a frequency of 3 ... 20 MHz
Effective capacitance	(pF/m) 30
Loop resistance (Ω/km)	≤ 110
Solid conductor	AWG 22/1
Flexible conductor	> 0.32 mm ²

As with the analog / HART version, you can parameterize the device using ASSET VISION DAT200 and DTM400 and FMT500-IG PROFIBUS-DTM.

Direct connection to intrinsically safe PROFIBUS DP lines is permitted, provided you use approved models and comply with safety-related parameters in accordance with certificates (see figure). The line length and number of bus nodes depend on the Ex barrier used.

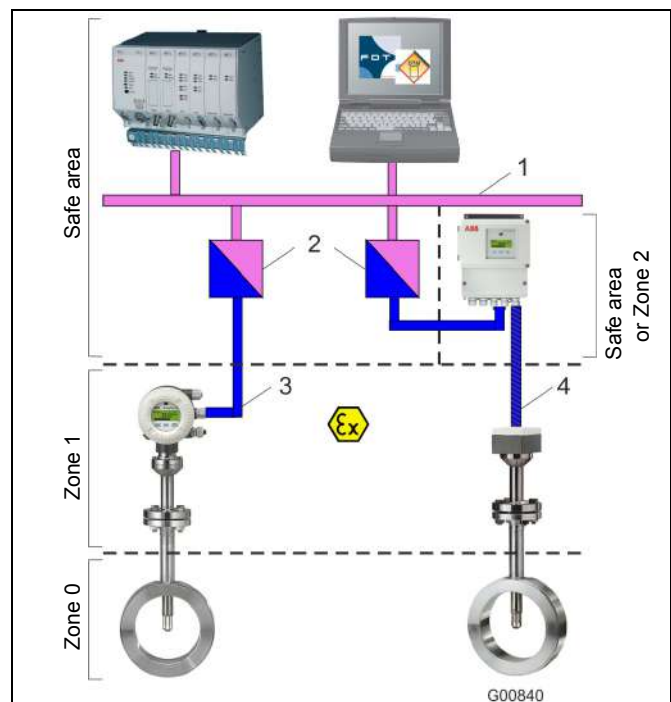

Fig. 5

- 1 PROFIBUS DPV1 non-intrinsically safe
- 2 Ex barrier PROFIBUS DP (RS 485_IS interface)
- 3 PROFIBUS DP intrinsically safe
- 4 Intrinsically safe circuit

6 Dimensions

Flowmeter sensor (integral mount design)	Transmitter (remote mount design)	Flowmeter sensor (remote mount design)
<p>G00841</p>	<p>G00842</p>	<p>G00797</p>
Type 1 pipe component: Wafer type	Type 2 pipe component: Measuring section	Weld-on adapter DN 100 (4") and higher
<p>G00798</p>	<p>G00799</p> <p>optional with integrated flow straightener</p>	<p>Ø 33.7 (1.33") (DN 25, PN 40)</p>

EN 1092-1 form B1, PN 40									
Nominal diameter		L2	h	D1	d1	d2	D4	L3	L4
DN 25	B1 = 125 (4.92)	269 (10.59)	263 (10.35)	-	28.5 (1.12)	-	115 (4.53)	600 (23.62)	486 (19.13)
DN 40	B2 = 80 (3.15)			94 (3.70)	43.1 (1.70)	88 (3.46)	150 (5.91)	860 (33.86)	731 (28.78)
DN 50	B3 = Ø115 (4.53)			109 (4.29)	54.5 (2.15)	102 (4.02)	165 (6.50)	1000 (39.37)	837 (32.95)
DN 65	B4 = 58 (2.28)			129 (5.08)	70.3 (2.77)	122 (4.80)	185 (7.28)	1400 (55.12)	1190 (46.85)
DN 80	K1 = 150 (5.91)			144 (5.67)	82.5 (3.25)	138 (5.43)	200 (7.87)	1700 (66.93)	1450 (57.09)
DN 100	K3 = 206 (8.11)			170 (6.69)	107.1 (4.22)	162 (6.38)	235 (9.25)	2200 (86.61)	1870 (73.62)
DN 125	L1 = 188 (7.40)			196 (7.72)	131.7 (5.19)	188 (7.40)	270 (10.63)	2700 (106.3)	2300 (90.55)
DN 150	L5 = 450 (17.72)			226 (8.90)	159.3 (6.27)	218 (8.58)	300 (11.81)	3200 (125.98)	2720 (107.09)
DN 200	L6 = 310 (12.20)			293 (11.54)	206.5 (8.13)	285 (11.22)	375 (14.76)	4200 (165.35)	3580 (140.94)
DN 250	L7 = 65 (2.56)			431 (16.97)	425 (16.73)				
> 350	M1 = 208 (8.19)	781 (30.75)	775 (30.51)						
> 700	M2 = 265 (10.43) M3 = 139 (5.47)								
ASME B 16.5, Cl. 150 (ANSI), Sch 40 S									
1"	B1 = 125 (4.92)	269 (10.59)	263 (10.35)	-	26.6 (1.05)	-	108 (4.25)	560 (22.05)	454 (17.87)
1 1/2"	B2 = 80 (3.15)			85 (3.35)	40.9 (1.61)	73 (2.87)	127 (5.00)	864 (34.02)	741 (29.17)
2"	B3 = Ø115 (4.53)			103 (4.06)	52.6 (2.07)	92 (3.62)	154 (6.06)	1003 (39.49)	846 (33.31)
3"	B4 = 58 (2.28)			135 (5.31)	78.0 (3.07)	127 (5.00)	-	-	-
4"	K1 = 150 (5.91)			173 (6.81)	102.4 (4.03)	157 (6.18)	-	-	-
6"	K3 = 206 (8.11)			221 (8.70)	154.2 (6.07)	216 (8.50)	-	-	-
8"	L1 = 188 (7.40)			278 (10.94)	202.7 (7.98)	270 (10.63)	-	-	-
> 14"	L5 = 450 (17.72)			431 (16.97)	425 (16.73)				
> 28"	L6 = 310 (12.20)			781 (30.75)	775 (30.51)				
	L7 = 65 (2.56)								
	M1 = 208 (8.19) M2 = 265 (10.43) M3 = 139 (5.47)								

Dimensions in mm (inch)

ASME B 16.5, Cl. 300 (ANSI), Sch 40 S									
1"	B1 = 125 (4.92)	269 (10.59)	263 (10.35)	-	26.6 (1.05)	-	123.9 (4.88)	560 (22.05)	454 (17.87)
1 1/2"	B2 = 80 (3.15)			94 (3.70)	40.9 (1.61)	73 (2.87)	155.4 (6.12)	864 (34.02)	741 (29.17)
2"	B3 = Ø115 (4.53)			110 (4.33)	52.6 (2.07)	92 (3.62)	165.1 (6.50)	1003 (39.49)	846 (33.31)
3"	B4 = 58 (2.28)			148 (5.83)	78.0 (3.07)	127 (5.00)	-	-	-
4"	K1 = 150 (5.91)			180 (7.09)	102.4 (4.03)	157 (6.18)	-	-	-
6"	L1 = 188 (7.40)			249 (9.80)	154.2 (6.07)	216 (8.50)	-	-	-
8"	L5 = 450 (17.72)			307 (12.09)	202.7 (7.98)	270 (10.63)	-	-	-
	L6 = 310 (12.20)								
> 14"	L7 = 65 (2.56)	431 (16.97)	425 (16.73)						
> 28"	M1 = 208 (8.19)	781 (30.75)	775 (30.51)						
	M2 = 265 (10.43)								
	M3 = 139 (5.47)								

Dimensions in mm (inch)

7 Installation instructions

7.1 Weld-on adapter for Sensyflow FMT500-IG

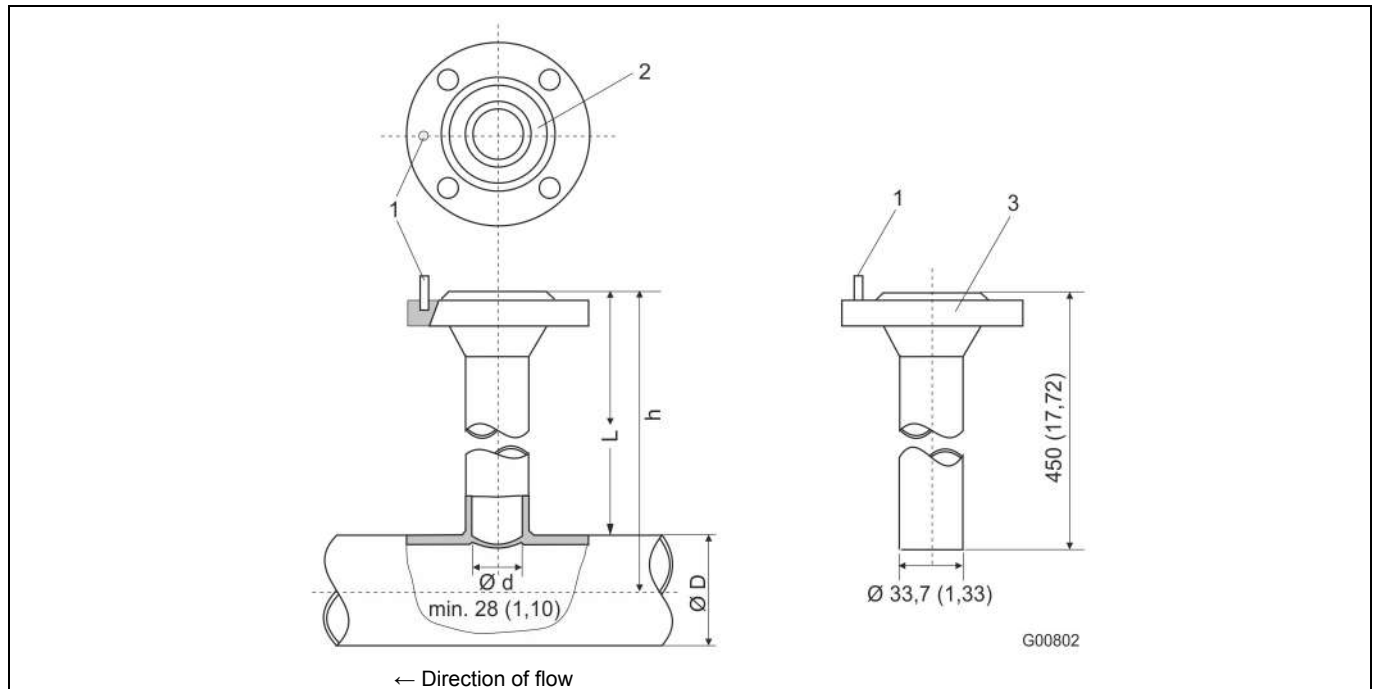

Fig. 6: Dimensions in mm (inch)

- 1 Centering pin
2 Sealing ring groove
3 Connection flange DN 25 (1")
D Outer pipe diameter

Flowmeter sensor length h in mm (inch)	Outer pipe diameter min. / max. in mm (inch)
263 (10.35)	100 ... 350 (3.94 ... 13.78)
425 (16.73)	> 350 ... 700 (13.78 ... 27.56)
775 (30.51)	> 700 ... 1400 (27.56 ... 55.12) ¹⁾

1) This maximum pipe diameter specification is only valid when installing the sensor unit centrally in the pipe. For larger diameters or angular ducts a non-centric sensor position is taken into account for calibration.



IMPORTANT (NOTE)

Prior to mounting the weld-on adapters must be shortened to length: $L = h - 1/2 D_{\text{outer}}$

The distance h between the upper flange edge and the pipe center line must be within a tolerance of ± 2 mm (0.08").

The right angle to the pipe center line must be observed (max. tolerance $\pm 2^\circ$).

The centering pin of the adapter must be aligned centrally with the pipe center line in flow direction (on outlet run side, downstream of the measuring point).

7.2 Weld-on adapter with ball valve for Sensyflow FMT500-IG



IMPORTANT (NOTICE)

The welding adapter with ball valve is not approved for use in potentially explosive atmospheres.

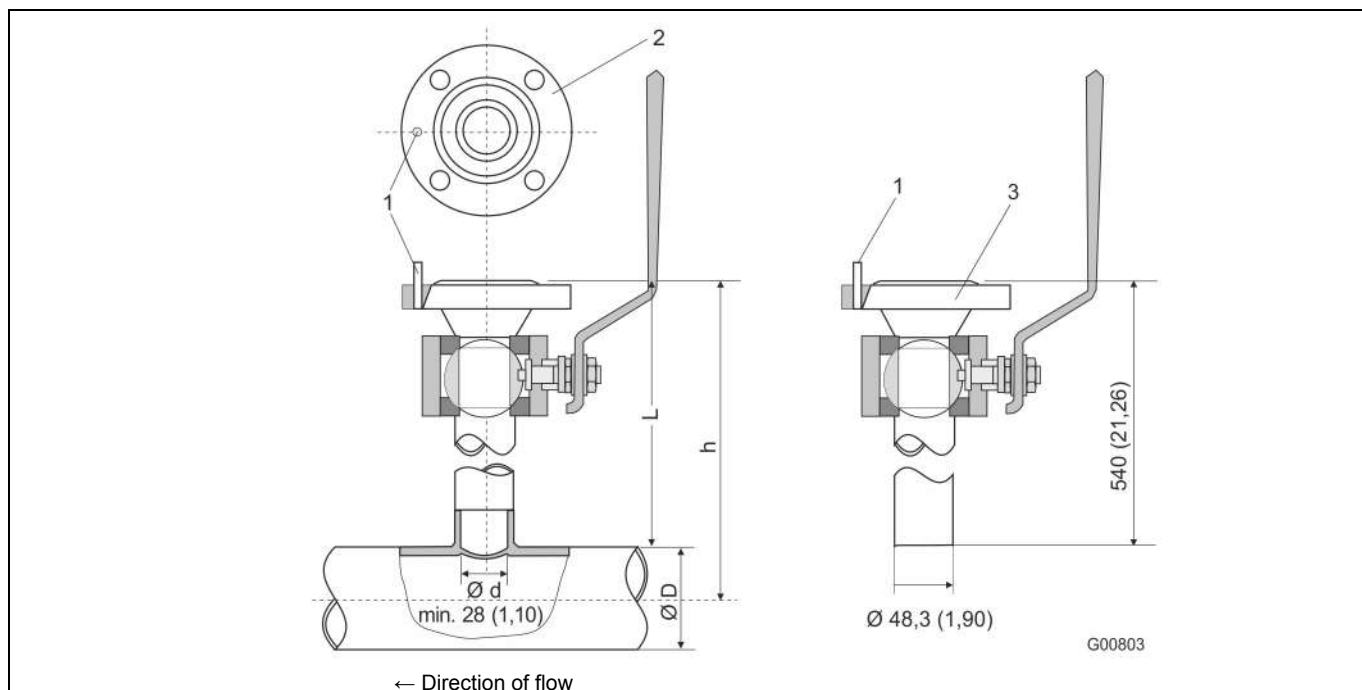

Fig. 7: Dimensions in mm (inch)

- | | |
|-----------------------|--------------------------------|
| 1 Centering pin | 3 Connection flange DN 25 (1") |
| 2 Sealing ring groove | D Outer pipe diameter |

Flowmeter sensor length h in mm (inch)	Outer pipe diameter min. / max. in mm (inch)
263 (10.35)	100 ... 150 (3.94 ... 5.91)
425 (16.73)	> 150 ... 500 (5.91 ... 19.69)
775 (30.51)	> 500 ... 1150 (19.69 ... 45.28) ¹⁾

¹⁾ This maximum pipe diameter specification is only valid when installing the sensor unit centrally in the pipe. For larger diameters or angular ducts a non-centric sensor position is taken into account for calibration.



IMPORTANT (NOTE)

Prior to mounting the weld-on adapters must be shortened to length: $L = h - 1/2 D_{\text{outer}}$

The distance h between the upper flange edge and the pipe center line must be within a tolerance of ± 2 mm (0.08").

The right angle to the pipe center line must be observed (max. tolerance $\pm 2^\circ$).

The centering pin of the adapter must be aligned centrally with the pipe center line in flow direction (on outlet run side, downstream of the measuring point).

7.3 Integrated hot tap fitting for Sensyflow FMT500-IG



IMPORTANT (NOTICE)

The integrated changing device is not approved for use in potentially explosive atmospheres.

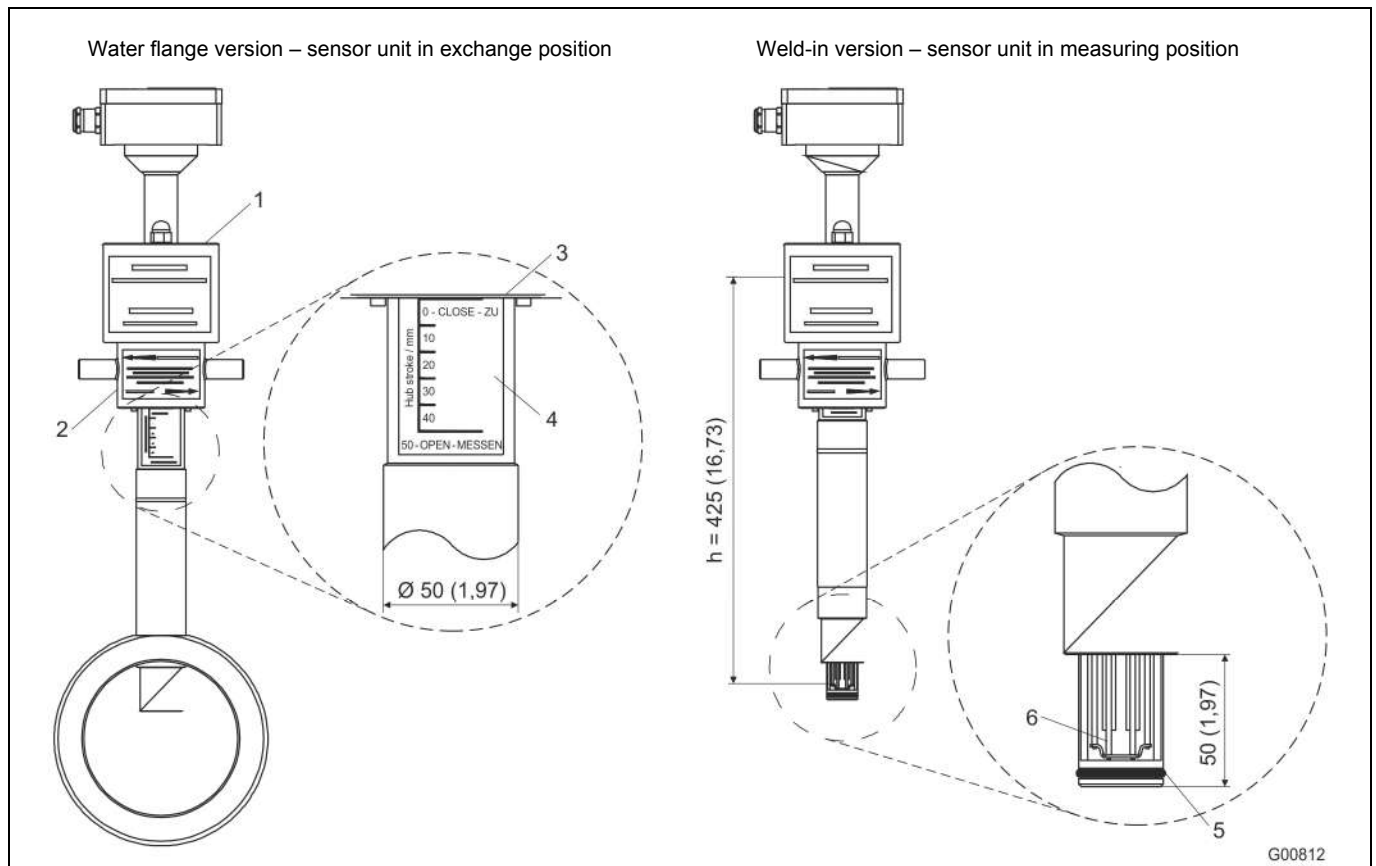

Fig. 8: Dimensions in mm (inch)

- | | |
|-----------------------------|---|
| 1 Covers for DN 25 flange | 4 Display of sensor unit position, 50 mm (1,97") stroke |
| 2 Spigot nur | 5 Sealing ring |
| 3 Bottom edge of spigot nut | 6 Sensor elements |

Flowmeter sensor length h	
Water flange version	Weld-in version
h = 263 mm (10.35") for DN 50, DN 65 and DN 80 / 2", 3" h = 425 mm (16.73") for DN 100, DN 125, DN 150 and DN 200 / 4", 6", 8"	h = always 425 mm (16.73")

The integrated hot tap fitting is used instead of the pipe component and weld-on adapter assembly described above if the flowmeter sensor must be exchangeable during operation with virtually no gas escaping from the system.

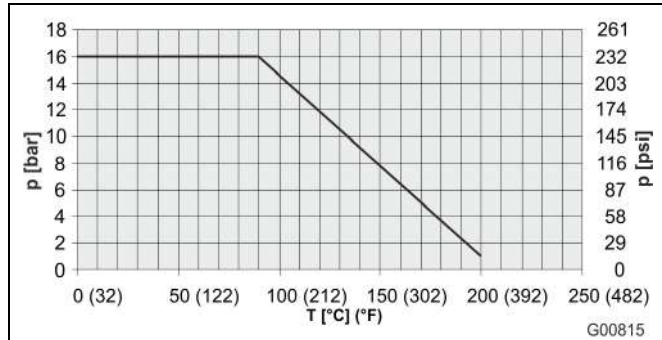

Fig. 9: Maximum pressure/temperature values for the integrated hot tap fitting

It is recommended to use the hot tap fitting for measurements in main conduits (e.g. compressed air systems) or for measuring points which otherwise require rinsing prior to removing the flowmeter sensor. As a rule, hot tap fittings should be preferred for all systems where, otherwise, the entire system or parts of it must be switched off to replace a flowmeter sensor.

Handling:

The flowmeter sensor is screwed to the hot tap fitting through the DN 25 flange. Then the cover is put on. The sensor unit is set from the exchange position to the measuring position by turning the spigot nut. The bottom edge of the spigot nut indicates the current sensor unit position (see Detail A, sensor unit is in exchange position). Only when the measuring position 50 – OPEN - MESSEN (lower stop of the spigot nut) is reached, the sensor elements are placed exactly in the center of the pipe and exact measurement is ensured.

i IMPORTANT (NOTE)

For integrated hot tap fitting in wafer flange design DN 65, use connection flange PN16 with 4 screw holes on the process side. Wafer flange versions 2 ... 8" only for connection flange ASME B16.5 Cl.150.

8 Recommended steadying lengths according to DIN EN ISO 5167-1

	<p>Expansion X = 15</p>
	<p>Reducer X = 15</p>
	<p>90° elbow X = 20</p>
	<p>Two 90° elbow in one level X = 25</p>
	<p>Two 90° elbow in two levels X = 40</p>
	<p>Valve / slide X = 50</p>

To achieve the stated measuring accuracy, the steadying lengths seen above must be provided. For combinations of inlet run disturbances, e. g. valve and reducer, you must always consider the longer inlet run length. In confined spaces at the mounting location the outlet run length can be shortened to 3 x D. The reduction of the minimum inlet run length, however, will impact on the achievable accuracy.

High repeatability of the measuring value is still provided. Under certain circumstances, special calibration can be performed for insufficient steadying lengths. For this purpose and in individual cases consulting is necessary.

For gases with extremely low density (hydrogen, helium) the steadying lengths must be doubled.

9 Ordering information

	Main order number											Add. order no.					
	7	8	9	10	11	12	13	14	15	16							
Version number 1 – 6																	
Sensyflow FMT500-IG Thermal Mass Flowmeter, for gases, intelligent	V14224	X	X	X	X	X	X	X	X	X	X	X	X	X	X	X	XXX
Version																	
Standard, -25 ... 150 °C (-13 ... 302 °F)		1															
High temperature version, -25 ... 300 °C (-13 ... 572 °F)		2															
ATEX version for Zone 2 / 22, -20 ... 150 °C (-4 ... 302 °F)	1)	3															
ATEX version for Zone 1 / 21, -20 ... 150 °C (-4 ... 302 °F)	2)	4															
ATEX version for Zone 0 / 21, -20 ... 80 °C (-4 ... 176 °F)		5															
FM version Cl. 1 Div 2, -20 ... 150 °C (-4 ... 302 °F) (remote version only)		6															
FM version Cl. 1 Div 1 / 2, -20 ... 150 °C (-4 ... 302 °F) (compact version only)		7															
Measured medium																	
Gases, gas mixtures and natural gas (with max. 23.5 Vol% O2 each)																	A
Oxygen / gas mixtures > 23.5 Vol% O2, oil and grease-free, with O2 certificate (max. 150 °C / 302 °F)																	B
Hydrogen, Helium (max. 8 bar / 0.8 MPa / 116 psi, always with process gas calibration)	3)																D
Ammonia Application																	E
Sensor unit																	
Ceramic sensor																	1
Mounting Length / Material																	
263 mm (10.4 in.) / AISI 316Ti SST (1.4571) (DN 25 ... DN 350 [1 ... 14 in.])																	4) 1
425 mm (17 in.) / AISI 316Ti SST (1.4571) (> DN 350 ... DN 700 [> 14 ... 28 in.])																	4) 2
775 mm (31 in.) / AISI 316Ti SST (1.4571) (> DN 700 [> 28 in.])																	4) 3
Power supply																	
Universal power supply 110 ... 230 V AC / DC																	5) 1
Low voltage power supply 24 V AC / DC																	6) 2
Design																	
Compact design with display, controlled via magnetic pen and keypad																	1
Remote design with display, controlled via magnetic pen and keypad (for required cable see accessories)																	7) 2
Communication																	
Analog signal 4 ... 20 mA / HART, alarm < 3.5 mA ,2 digital outputs (frequency, pulse, switch contact), 2 digital inputs (switch contact)																	1
Analog signal 4 ... 20 mA / HART, alarm > 22 mA (Default Setting), 2 digital outputs (frequency, pulse, switch contact), 2 digital inputs (switch contact)																	4
Analog signal 0 ... 20 mA, 2 digital outputs (frequency, pulse, switch contact), 2 digital inputs (switch contact)																	5
PROFIBUS DPV1, direct connection of bus cable (for further bus auxiliary components see PROFIBUS list / service)																	2
PROFIBUS DPV1, with DP M12 connector socket (for further bus auxiliary components see PROFIBUS list / service)																	8) 3
Cable gland																	
M20 x 1.5																	1
1/2 in. NPT																	2
Number of Characteristic Curves																	
1 characteristic curve																	1
2 characteristic curves																	2
3 characteristic curves																	3
4 characteristic curves																	4
Certificates: Calibration																	
Factory certificate																	0
DAkS certificate, calibration with air (not for process gas calibration)																	9) 1

Continued on next page

	Version number	Main order number										Add. order no.					
		1	2	3	4	5	6	7	8	9	10		11	12	13	14	15
Sensyflow FMT500-IG Thermal Mass Flowmeter, for gases, intelligent	V14224	X	X	X	X	X	X	X	X	X	X	X	X	X	X	X	XXX
Certificates and Material Traceability																	
Material certificate 3.1 acc. EN 10204																	CBB
Declaration of compliance with the order 2.1 acc. EN 10204																	CF3
Certificates: SIL																	
SIL1 - Declaration of Conformity																	CS1
Signal cable length																	
Ohne																	SC0
5 m (approx. 15 ft)															10)		SC1
15 m (approx. 45 ft)															10)		SC3
25 m (approx. 75 ft)															10)		SC5
Language of documentation																	
German																	M1
English																	M5
Russian																	MB
Language package Western Europe / Scandinavia (languages: DE, EN, DA, ES, FR, IT, NL, PT, FI, SV)																	MW
Language package Eastern Europe (languages: DE, EL, CS, ET, LV, LT, HU, PL, SK, SL, RO, BG)																	ME

Accessories	Order number
FMT500-IG Special cable between flowmeter sensor and transmitter, cable length 5 m	7962844
FMT500-IG Special cable between flowmeter sensor and transmitter, cable length 15 m	7962845
FMT500-IG Special cable between flowmeter sensor and transmitter, cable length 25 m	7962846
FMT500-IG PROFIBUS DP-T connector plug	7962847
FMT500-IG PROFIBUS DP socket, for customizing the bus cable	7962848
FMT500-IG PROFIBUS DP connector, for customizing the bus cable	7962849
FMT500-IG Documentation CD-ROM	3KXF421002R0800
FMT500-IG Commissioning Instruction, English	3KXF421008R4401
FMT500-IG Commissioning Instruction, German	3KXF421008R4403
FMT500-IG Commissioning Instruction, Language package Eastern Europe	3KXF421008R4494
FMT500-IG Commissioning Instruction, Language package Western Europe / Scandinavia	3KXF421008R4493
FMT500-IG Operating Instruction, Russian	3KXF421008R4222
FMT500-IG SIL-Safety Instructions, English	3KXF421000R4801
FMT500-IG SIL-Safety Instructions, German	3KXF421000R4803

- 1) Manufacturer's declaration
- 2) The max. allowed gas temperature / process temperature depends on the temperature class: T1 / T2 max. 150 °C (302 °F), T3 / T4 max. 100 °C (212 °F)
- 3) With measuring medium H2 or He, lower measuring range limit typical 10% of upper limit, in nominal size DN 25 ... DN 50 (1 ... 2 in.):
Please use pipe component design 2 with flow straightener
- 4) Nominal size ranges when using pipe components or weld-on adapters without ball valve
- 5) +/- 10 % (f = 48 ... 62 Hz)
- 6) +/- 20 % (f = 48 ... 62 Hz)
- 7) With ATEX versions: wall housing with operating electronics can be mounted in Ex zone 2
- 8) For non-Ex / compact versions only
- 9) DAkkS- / ILAC-accredited calibration equipment D-K-15081-01-00
- 10) Only for Remote Version

	Main order number									Add. order no.
	Version number	1 - 6	7-9	10	11	12	13	14	15	
FMT081 pipe component / weld-on adapter, for Sensyflow FMT500-IG and FMT400-VTS	FMT081	XXX	X	X	X	X	X	X	X	XXX
Mounting Length of the Sensor										
263 mm (10.4 in.)		263								
425 mm (17 in.)		425								
775 mm (31 in.)		775								
Measuring Medium										
Gases, gas mixtures, and natural gas (each max. 23.5 vol% O2)				A						
Oxygen / gas mixtures > 23.5 Vol% O2, oil and grease-free, with O2 certificate (max. 150 °C / 302 °F)				B						
Natural gas, with DVGW certificate (max. 80 °C / 176 °F)				C						
Hydrogen, Helium				1) D						
Design										
Pipe component 1 in wafer flange version					1					
Pipe component design 2 as partial measuring section					2					
Pipe component design 2 as partial measuring section with integrated flow straighteners						3				
Weld-on adapter				2)	4					
Other					9					
Nominal Diameter										
Selection for weld-on adapter							Y			
DN 25 (1 in.)					3)	A				
DN 40 (1-1/2 in.)					4)	C				
DN 50 (2 in.)						D				
DN 65 (2-1/2 in.)					5)	E				
DN 80 (3 in.)					6)	F				
DN 100 (4 in.)					6)	G				
DN 125 (5 in.)					6)	H				
DN 150 (6 in.)					6)	J				
DN 200 (8 in.)					6)	L				
DN 250 (10 in.)					7)	M				
DN 300 (12 in.)					7)	N				
Other					8)	Z				
Flange Style and Pressure Rating										
Selection for weld-on adapter								0		
DIN PN 40, nominal pressure 40 bar (4 MPa / 580 psi)								1		
ANSI / ASME CL 150, Schedule 40 S								2		
ANSI / ASME CL 300, Schedule 40 S							4)	3		
Other								9		
Process Connection for Flowmeter Sensor										
Standard Sensyflow flange with centering pin							9)	A		
With ball valve, max. 150 °C (302 °F) and 16 bar (1.6 MPa / 232 psi)							10)	G		
With integrated hot tap fitting for max. DN 125 (5 in.). Allows gas-tight flowmeter sensor removal / insertion up to 16 bar (1.6 MPa / 232 psi) or 200 °C (392 °F). For DN 65, use connection flanges PN 16 with 4 screw holes (For pipe component DN 50 ... DN 80, apply Sensor Length h = 263 mm, from DN 100 and for weld-on adapter, apply Sensor Length h = 425 mm)							11)	H		
With integrated hot tap fitting above DN 125 (5 in.) to max. DN 200 (8 in.) / DN 300 (12 in.) with weld-on adapter. Allows gas-tight flowmeter sensor removal / insertion up to 16 bar (1.6 MPa / 232 psi) or 200 °C (392 °F) (Please apply the correct sensor length)							12)	J		
Material										
Stainless steel AISI 316Ti (1.4571)									3	
Carbon steel S 235 (1.0037)									13)	1
Plastics PE-HD (Polyethylene high-density)									13)	7
Blind Flange										
DN 25 blind flange to close flowmeter sensor connection, material stainless steel AISI 316Ti (1.4571)										F3
Certificates and Material Traceability										
Material certificate 3.1 acc. EN 10204										CBB
Declaration of compliance with the order 2.1 acc. EN 10204										CF3

Footnotes see next page

- 1) Max. 8 bar / 0.8 MPa / 116 psi. With DN 25 ... DN 50 (1 ... 2 in.): Please use pipe component 2 with flow straightener.
- 2) From DN 100 (4 in.).
- 3) Not available with pipe component 1 in wafer flange version.
- 4) Not available with hot-tap-fitting.
- 5) Not available with flange style ANSI / ASME.
- 6) Not available with pipe component 2 in combination with flange style ANSI / ASME.
- 7) Not available with pipe component 2 and not available with flange style ANSI / ASME
- 8) Please specify exact inner pipe diameter.
- 9) Correct sensor length: For pipe component 1 and 2: h = 263 mm. For weld-on adapter and pipe diameter up to 350 mm: h = 263 mm, up to 700 mm: h = 425 mm, > 700 mm: h = 775 mm
- 10) Not available with DVGW certificate. Correct sensor length: For pipe component DN 25 ... DN 100: h = 263 mm, from DN 125: h = 425 mm. For weld-on adapter up to diameter 150 mm: h = 263 mm, up to 500 mm: h = 425 mm, > 500 mm: h = 775 mm
- 11) Not available with DVGW certificate. Not available with pipe component design 2 in flange style ANSI / ASME.
- 12) Not available with DVGW certificate. Not available with pipe component design 2 in flange style ANSI / ASME. Not available with pipe component design 2 in flange style DIN.
- 13) Only for weld-on adapter without ball-valve. Only without certificates.

9.1 Additional ordering information

FMT500-IG		
Gas component 1	Vol. %	(clear text, for max. 4 characteristics)
Gas component 2	Vol. %	(clear text, for max. 4 characteristics)
Gas component 3	Vol. %	(clear text, for max. 4 characteristics)
Gas component 4	Vol. %	(clear text, for max. 4 characteristics)
Gas component 5	Vol. %	(clear text, for max. 4 characteristics)
Gas component 6	Vol. %	(clear text, for max. 4 characteristics)
Gas component 7	Vol. %	(clear text, for max. 4 characteristics)
Gas component 8	Vol. %	(clear text, for max. 4 characteristics)
Gas component 9	Vol. %	(clear text, for max. 4 characteristics)
Gas component 10	Vol. %	(clear text, for max. 4 characteristics)
Summe 100 %		
Operating temperature		(clear text, for max. 4 characteristics)
Operating pressure		(clear text, for max. 4 characteristics)
Nominal size, Pipe inner diameter		(clear text, for max. 4 characteristics)
Measuring range		(clear text, for max. 4 characteristics)
Unit ¹⁾		(clear text, for max. 4 characteristics)
Standard conditions (e. g. 0 °C, 1013 mbar)		(clear text, for max. 4 characteristics)
Display and menu language (delivered state)		German, English, French, Portuguese
Material of the connected pipes		

- 1) Available flow rate units:

t/d	t/h	t/min	t/s
kg/d	kg/h	kg/min	kg/s
	g/h	g/min	g/s
lb/d	lb/h	lb/min	lb/s
Nm ³ /d	Nm ³ /h	Nm ³ /min	Nm ³ /s
NL/d	NI/h	NI/min	NI/s
SCFD	SCFH	SCFN	SCFS

10 Questionnaire



Questionnaire
Thermal Mass Flowmeter
Sensyflow FMT

Customer address: _____
 Company: _____
 Zip code and location: _____ Date: _____
 Cust. no.: _____ Telephone: _____
 Contact person: _____ E-mail: _____

Media data for gaseous, pure media:

Description of media _____ Mixed gas, gas composition in vol.%¹⁾

Type of gas (no mixtures): _____ Component 1/name/vol. %: _____
 Operating pressure (bar abs.) _____ Component 2/name/vol. %: _____
 Min./norm./max., approx. _____ Component 3/name/vol. %: _____
 Operating temperature (°C) _____ Component 4/name/vol. %: _____
 Min./norm./max., approx. _____ Component 5/name/vol. %: _____

Flowrate²⁾ Min.: _____ Norm.: _____ Max.: _____ **Pipeline/pipe component**³⁾

Flow unit:

	<i>Standard volume</i>	<i>Mass flow units</i>	
Nm ³ /h	<input type="checkbox"/>	kg/h	<input type="checkbox"/>
Nm ³ /min	<input type="checkbox"/>	kg/min	<input type="checkbox"/>
NI/min	<input type="checkbox"/>	g/min	<input type="checkbox"/>
SCFM	<input type="checkbox"/>	t/h	<input type="checkbox"/>
Other _____		Other _____	

*Standard condition, e.g., 0°C/1,013 mbar or _____

DN/PN: _____
 ANSI/lbs _____
 Diameter [mm] _____
Inside diameter specified in mm
 Wafer flange form 1
 Partial meas. section form 2
 Weld-on adapter
 Other _____

Required device designs:

FMT500-IG <input type="checkbox"/>	FMT700-P ⁴⁾ <input type="checkbox"/>	Design:
FMT400-VTS <input type="checkbox"/>	FMT200-ECO2 <input type="checkbox"/>	Integral mount design <input type="checkbox"/>
FMT400-VTCS <input type="checkbox"/>	FMT200-D <input type="checkbox"/>	Remote design with
		Cable length 5 m <input type="checkbox"/>
		Cable length 15 m <input type="checkbox"/>
		Cable length 25 m <input type="checkbox"/>

Output signal: **Ex protection class:**

0/4...20 mA <input type="checkbox"/>	None <input type="checkbox"/>	Zone 2/22 <input type="checkbox"/>	24 V <input type="checkbox"/>
4...20 mA/HART <input type="checkbox"/>	ATEX Zone 1/21 <input type="checkbox"/>	GOST <input type="checkbox"/>	110 V <input type="checkbox"/>
PROFIBUS DP-V1 <input type="checkbox"/>	ATEX Zone 0/21 <input type="checkbox"/>	FM/CSA <input type="checkbox"/>	230 V <input type="checkbox"/>

Comments:

1) Please specify the composition of mixed gases (e.g., North Sea natural gas: 1) CH₄ 90%, 2) C₂H₆ 5%, 3) N₂ 3%, 4) C₃H₈, 1%, 5) CO₂ 1%).
 2) Calibration is performed at the max. possible flow in the nominal size specified.
 3) Please observe/determine the minimum inflow and outflow sections.
 4) Output signal: 0...10 V as standard

Note: An order can only be confirmed and a delivery date specified once full technical clearance has been obtained.

ABB Limited**Measurement & Analytics**

Howard Road, St. Neots
Cambridgeshire, PE19 8EU
UK

Tel: +44 (0)870 600 6122

Fax: +44 (0)1480 213 339

Email: enquiries.mp.uk@gb.abb.com

ABB Inc.**Measurement & Analytics**

125 E. County Line Road
Warminster, PA 18974
USA

Tel: +1 215 674 6000

Fax: +1 215 674 7183

ABB Automation Products GmbH**Measurement & Analytics**

Schillerstr. 72
32425 Minden
Germany

Tel: +49 571 830-0

Fax: +49 571 830-1806

abb.com/flow

We reserve the right to make technical changes or modify the contents of this document without prior notice. With regard to purchase orders, the agreed particulars shall prevail.
ABB does not accept any responsibility whatsoever for potential errors or possible lack of information in this document.

We reserve all rights in this document and in the subject matter and illustrations contained therein. Any reproduction, disclosure to third parties or utilization of its contents – in whole or in parts – is forbidden without prior written consent of ABB.